

| LOC | | DIST | | REVISIONS | | | |
|-----|-----|---------------------------|-----------|-----------|------|--|--|
| P | LTR | DESCRIPTION | DATE | DWN | APVD | | |
| | S2 | REVISED PER ECO-15-006450 | 28APR2015 | NK | RH | | |

SPECIFICATIONS:

MATERIAL
 BASE, PPS, UL94V-0, BLACK
 COVER, PPS, UL94V-0, BLACK
 ACTUATOR, PA6T, UL94V-0, WHITE
 FIXED CONTACT/TERMINAL, CU ALLOY-GOLD FLASH OVER NICKEL
 MOVING CONTACT, CU ALLOY, PLATE-GOLD FLASH/NICKEL

ELECTRICAL
 MAX CONTACT RATING SWITCHING, 100MILLIAMP @ 24 VDC
 MIN CONTACT RATING SWITCHING, .1MICROAMP @ 1 MILLIVOLT
 MAX CONTACT NON-SWITCHING, 1AMP @ 5 VDC
 INITIAL CONTACT RESISTANCE, 50 MILLIOHMS MAX.
 CONTACT RESISTANCE (AFTER ENVIRONMENTAL TEST), 100 MILLIOHMS
 CONTACT RESISTANCE (AFTER GAS TEST), 300 MILLIOHMS
 INSULATION RESISTANCE, 1,000 MEGOHMS MIN. @ 100 VDC
 DIELECTRIC STRENGTH, 500 VAC RMS @ SEA LEVEL
 LIFE EXPECTANCY, 1,000 CYCLES

MECHANICAL
 OPERATING FORCE, LESS THAN 800 GRAMS
 CONTACT PRESSURE, 280,000 PSI

ENVIRONMENTAL
 OPERATING TEMPERATURE, -30 TO +85 DEGREES C
 STORAGE TEMPERATURE, -45 TO +105 DEGREES C
 CLEANING, AQUEOUS OR SOLVENT
 SOLDER HEAT RESISTANCE, PER 109-201, COND B, SWITCH "OFF".
 SOLDERABILITY PER JIS C 0050 & JIS C 0053

- SWITCHES TO BE RECEIVED IN THE "OFF" POSITION AND PACKAGED IN CLEAR TUBES TO ACCOMMODATE AUTO-INSERTION.
- TOP SURFACE TO BE CLEARLY MARKED AS SHOWN.
- SWITCHES TO BE BLACK WITH WHITE ACTUATORS AND MARKINGS.
- △ TERMINAL OPTION: OLD T&B P/N ADExxS, SA OR SB
 S= OUTSIDE "L" TERMINALS; SA= INSIDE "L" TERMINALS;
 SB= BUTT TERMINALS.
- ALL MATERIALS AND FINISHES SHALL COMPLY WITH EU DIRECTIVE 2002/95/EC OF 27JAN2003 (ROHS).
- △ OBSOLETE PARTS: OBSOLETE CIS STREAMLINING PER D.RENAUD/D.SINISI.
- △ TAPE AND REEL PACKING PER PAGE 3 SPECIFICATIONS.

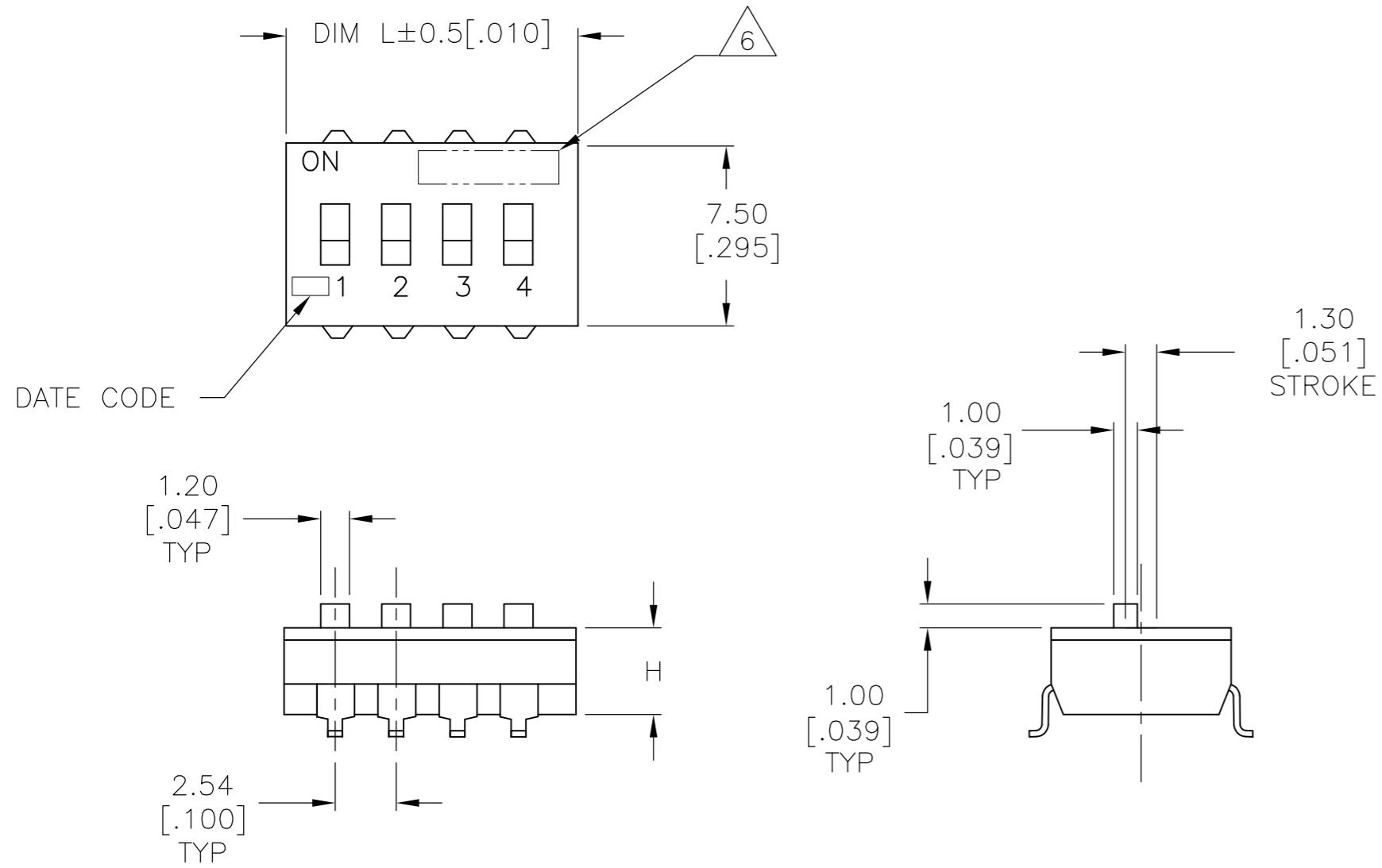

SEE SHEET 2 FOR PART NUMBER TABLE AND MOUNTING OPTIONS

| | | | | | | | | | | | | | | | | | | | | | | |
|--|---|----------------------------------|----------------------------|---------------|-------|---|---|-------|---|-------------|-------|---|---|-------|---|---|--------|---|---|--------------|------|-----------|
| THIS DRAWING IS A CONTROLLED DOCUMENT. | | DWN B.S.VISWESWARA 10FEB05 | TE Connectivity | | | | | | | | | | | | | | | | | | | |
| DIMENSIONS: mm [INCHES] | | CHK M.SARVER | | | NAME | | | | | | | | | | | | | | | | | |
| TOLERANCES UNLESS OTHERWISE SPECIFIED: | | APVD M.SARVER | DIP SWITCH, ADE-SMT SERIES | | | | | | | | | | | | | | | | | | | |
| <table border="1"> <tr><td>0 PLC</td><td>±</td><td>-</td></tr> <tr><td>1 PLC</td><td>±</td><td>-</td></tr> <tr><td>2 PLC</td><td>±</td><td>0.30[0.012]</td></tr> <tr><td>3 PLC</td><td>±</td><td>-</td></tr> <tr><td>4 PLC</td><td>±</td><td>-</td></tr> <tr><td>ANGLES</td><td>±</td><td>-</td></tr> </table> | | 0 PLC | ± | - | 1 PLC | ± | - | 2 PLC | ± | 0.30[0.012] | 3 PLC | ± | - | 4 PLC | ± | - | ANGLES | ± | - | PRODUCT SPEC | SIZE | CAGE CODE |
| 0 PLC | ± | - | | | | | | | | | | | | | | | | | | | | |
| 1 PLC | ± | - | | | | | | | | | | | | | | | | | | | | |
| 2 PLC | ± | 0.30[0.012] | | | | | | | | | | | | | | | | | | | | |
| 3 PLC | ± | - | | | | | | | | | | | | | | | | | | | | |
| 4 PLC | ± | - | | | | | | | | | | | | | | | | | | | | |
| ANGLES | ± | - | | | | | | | | | | | | | | | | | | | | |
| MATERIAL | | FINISH | WEIGHT | DRAWING NO | | | | | | | | | | | | | | | | | | |
| - | | - | - | RESTRICTED TO | | | | | | | | | | | | | | | | | | |
| CUSTOMER DRAWING | | | SCALE | SHEET | | | | | | | | | | | | | | | | | | |
| | | | 4:1 | 1 of 3 | | | | | | | | | | | | | | | | | | |
| | | | REV | S2 | | | | | | | | | | | | | | | | | | |

THIS DRAWING IS UNPUBLISHED. RELEASED FOR PUBLICATION 1825058, 1825058
 © COPYRIGHT 1825058 By - ALL RIGHTS RESERVED.

| LOC | | DIST | | REVISIONS | | | | |
|-----|-----|-------------|------|-----------|------|--|--|--|
| P | LTR | DESCRIPTION | DATE | DWN | APVD | | | |
| AD | 0 | SEE SHEET 1 | - | - | - | | | |

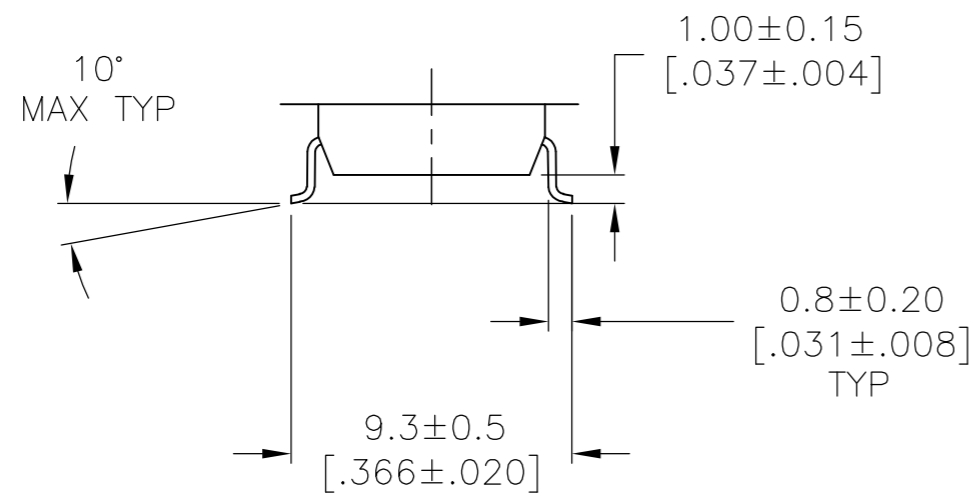
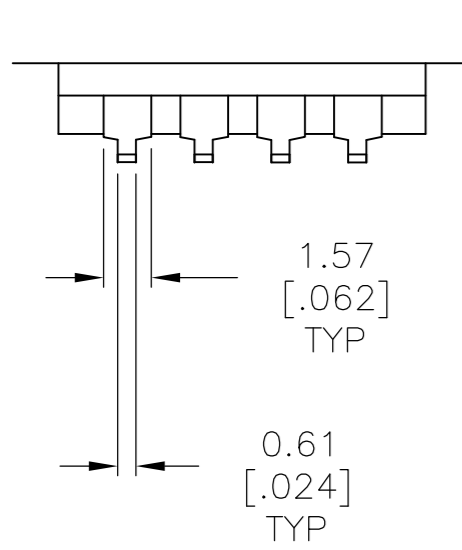

SURFACE MOUNT S (OUTSIDE "L")

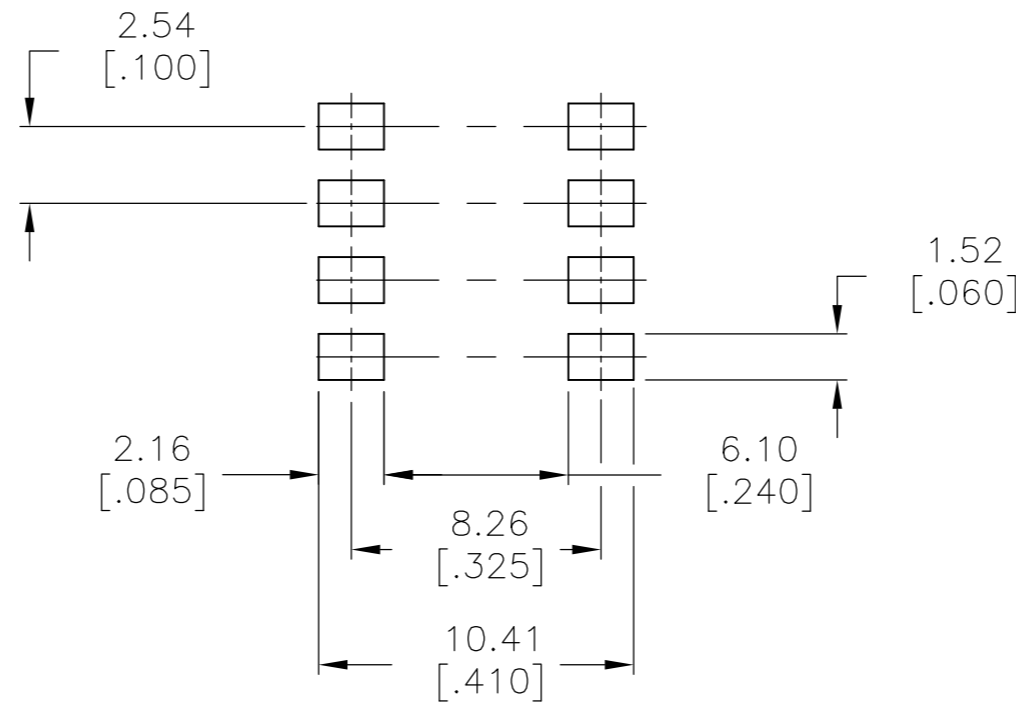

RECOMMENDED PAD LAYOUT

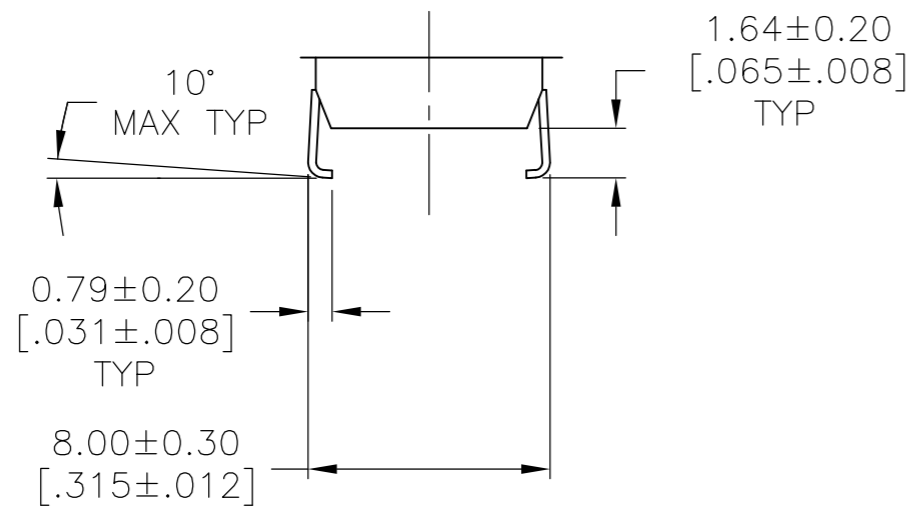
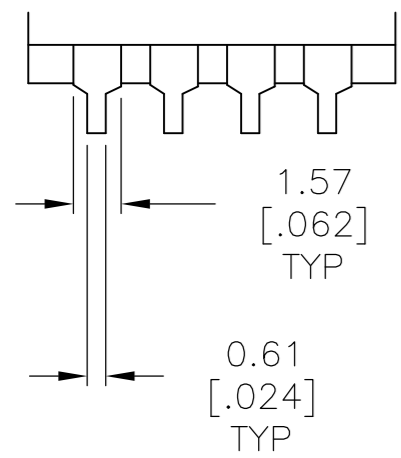

SURFACE MOUNT SA (INSIDE "L")

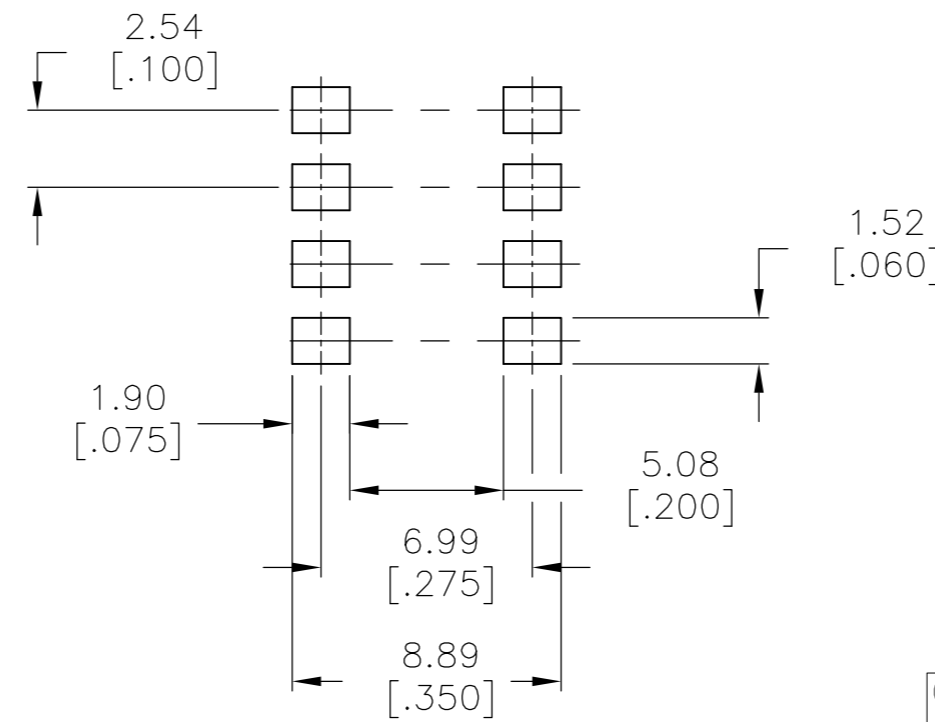

RECOMMENDED PAD LAYOUT

| | | | | | |
|----------------------|-------------|---------------|-------|-------------|----------|
| ADE12STR04 | 3.61 [.142] | 32.51 [1.280] | 12 | 4-1825058-1 | |
| ADE10STR04 | 3.50 [.138] | 27.30 [1.075] | 10 | 4-1825058-0 | |
| ADE09STR04 | 3.50 [.138] | 24.54 [.978] | 9 | 3-1825058-9 | |
| ADE08STR04 | 3.50 [.138] | 22.30 [.878] | 8 | 3-1825058-8 | |
| ADE07STR04 | 3.50 [.138] | 19.76 [.778] | 7 | 3-1825058-7 | |
| ADE06STR04 | 3.50 [.138] | 17.22 [.678] | 6 | 3-1825058-6 | |
| ADE05STR04 | 3.50 [.138] | 14.68 [.578] | 5 | 3-1825058-5 | |
| ADE04STR04 | 3.50 [.138] | 12.14 [.478] | 4 | 3-1825058-4 | |
| ADE03STR04 | 3.50 [.138] | 9.60 [.378] | 3 | 3-1825058-3 | |
| ADE02STR04 | 3.50 [.138] | 7.00 [.276] | 2 | 3-1825058-2 | |
| ADE04SATR04 | 3.50 [.138] | 12.14 [.478] | 4 | 3-1825058-1 | |
| ADE12SB04 | 3.61 [.142] | 32.51 [1.280] | 12 | 3-1825058-0 | |
| ADE12SA04 | 3.61 [.142] | 32.51 [1.280] | 12 | 2-1825058-9 | |
| ADE12S04 | 3.61 [.142] | 32.51 [1.280] | 12 | 2-1825058-8 | |
| ADE10SB04 | 3.50 [.138] | 27.30 [1.075] | 10 | 2-1825058-7 | |
| ADE10SA04 | 3.50 [.138] | 27.30 [1.075] | 10 | 2-1825058-6 | |
| ADE10S04 | 3.50 [.138] | 27.30 [1.075] | 10 | 2-1825058-5 | |
| ADE09SB04 | 3.50 [.138] | 24.54 [.978] | 9 | 2-1825058-4 | |
| ADE09SA04 | 3.50 [.138] | 24.54 [.978] | 9 | 2-1825058-3 | |
| ADE09S04 | 3.50 [.138] | 24.54 [.978] | 9 | 2-1825058-2 | |
| ADE08SB04 | 3.50 [.138] | 22.30 [.878] | 8 | 2-1825058-1 | |
| ADE08SA04 | 3.50 [.138] | 22.30 [.878] | 8 | 2-1825058-0 | |
| ADE08S04 | 3.50 [.138] | 22.30 [.878] | 8 | 1-1825058-9 | |
| ADE07SB04 | 3.50 [.138] | 19.76 [.778] | 7 | 1-1825058-8 | |
| ADE07SA04 | 3.50 [.138] | 19.76 [.778] | 7 | 1-1825058-7 | |
| ADE07S04 | 3.50 [.138] | 19.76 [.778] | 7 | 1-1825058-6 | |
| ADE06SB04 | 3.50 [.138] | 17.22 [.678] | 6 | 1-1825058-5 | |
| ADE06SA04 | 3.50 [.138] | 17.22 [.678] | 6 | 1-1825058-4 | |
| ADE06S04 | 3.50 [.138] | 17.22 [.678] | 6 | 1-1825058-3 | |
| ADE05SB04 | 3.50 [.138] | 14.68 [.578] | 5 | 1-1825058-2 | |
| ADE05SA04 | 3.50 [.138] | 14.68 [.578] | 5 | 1-1825058-1 | |
| ADE05S04 | 3.50 [.138] | 14.68 [.578] | 5 | 1-1825058-0 | |
| ADE04SB04 | 3.50 [.138] | 12.14 [.478] | 4 | 1825058-9 | |
| ADE04SA04 | 3.50 [.138] | 12.14 [.478] | 4 | 1825058-8 | |
| ADE04S04 | 3.50 [.138] | 12.14 [.478] | 4 | 1825058-7 | |
| ADE03SB04 | 3.50 [.138] | 9.60 [.378] | 3 | 1825058-6 | |
| ADE03SA04 | 3.50 [.138] | 9.60 [.378] | 3 | 1825058-5 | |
| ADE03S04 | 3.50 [.138] | 9.60 [.378] | 3 | 1825058-4 | |
| ADE02SB04 | 3.50 [.138] | 7.00 [.276] | 2 | 1825058-3 | |
| ADE02SA04 | 3.50 [.138] | 7.00 [.276] | 2 | 1825058-2 | |
| ADE02S04 | 3.50 [.138] | 7.00 [.276] | 2 | 1825058-1 | |
| T&B P/N | | DIM H | DIM L | POSITION | PART NO. |

THIS DRAWING IS A CONTROLLED DOCUMENT. DWN: B.S.VISWESWARA 10FEB05
 CHK: M.SARVER
 APVD: M.SARVER
 PRODUCT SPEC: -
 APPLICATION SPEC: -
 MATERIAL: - FINISH: - WEIGHT: -

STE TE Connectivity
 DIP SWITCH, ADE-SMT SERIES

SIZE: A2 CAGE CODE: - DRAWING NO: C=1825058 RESTRICTED TO: -
 SCALE: 4:1 SHEET: 2 OF 3 REV: S2

THIS DRAWING IS UNPUBLISHED. RELEASED FOR PUBLICATION 1825058, 1825058
 © COPYRIGHT 1825058 By - ALL RIGHTS RESERVED.

| LOC | DIST | REVISIONS | | | | | |
|-----|------|-----------|-----|-------------|------|-----|------|
| AD | 0 | P | LTR | DESCRIPTION | DATE | DWN | APVD |
| | | - | - | SEE SHEET 1 | - | - | - |

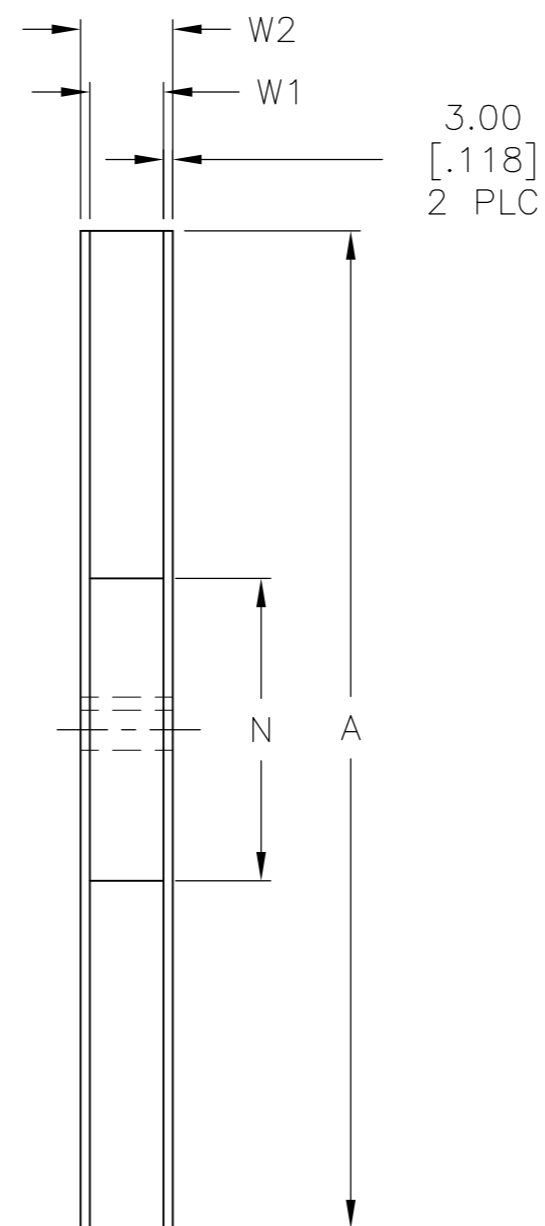
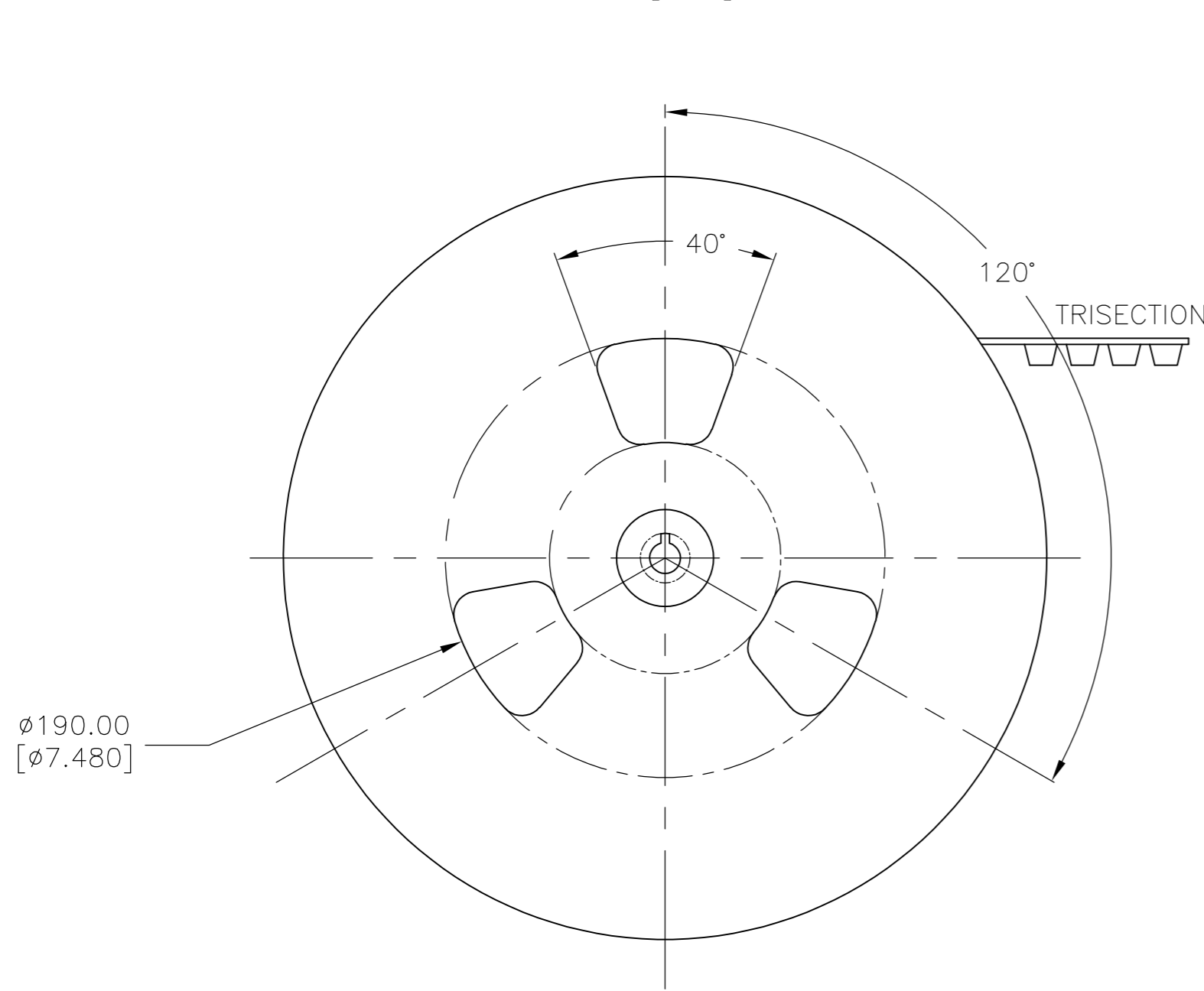
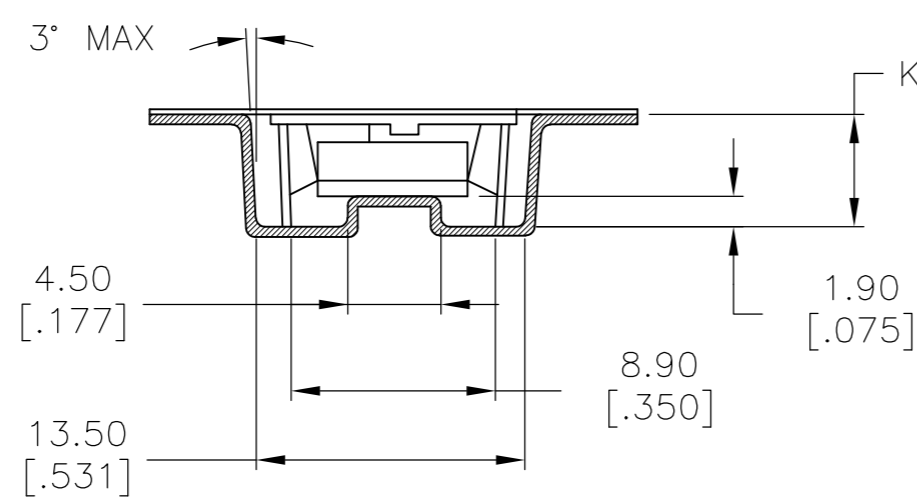
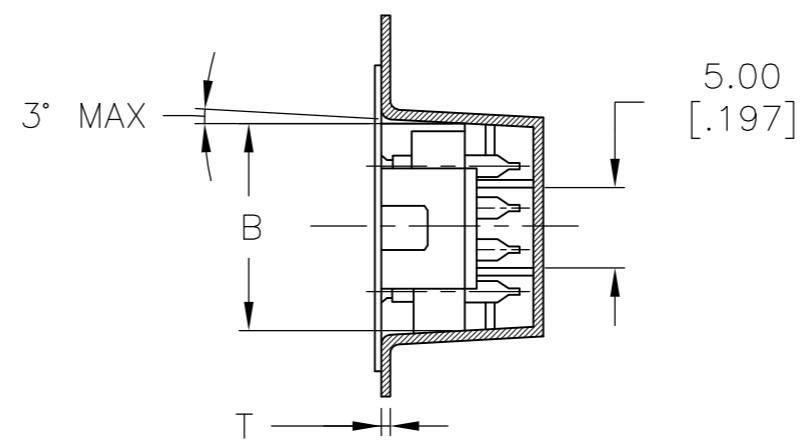
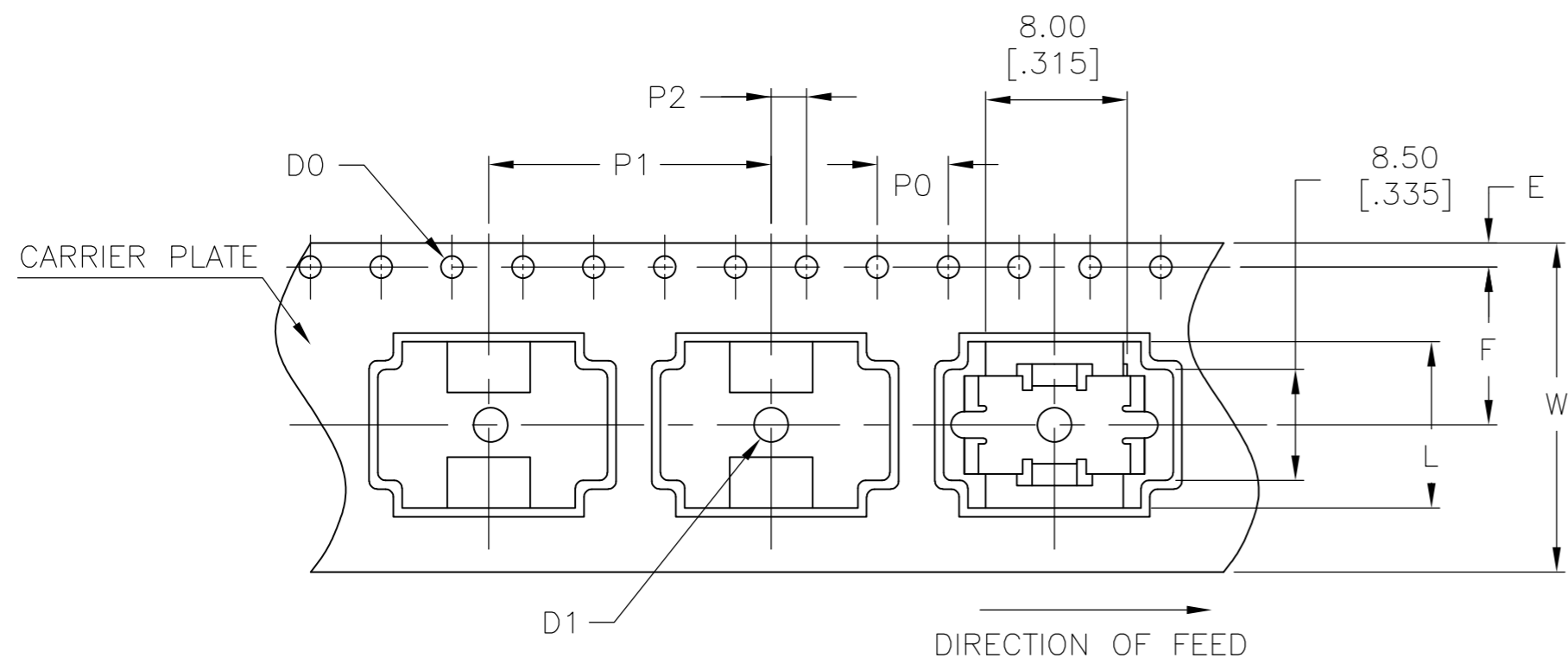

| | DESCRIPTION | MATERIAL | DIMENSION | FINISH | REMARKS |
|---|----------------|------------------------------------|-----------------|------------|-------------|
| 1 | REEL | SIDE: CARDBOARD CORE: STYLOFOAM | MENTIONED BELOW | | |
| 2 | EMBOSSSED TAPE | - | MENTIONED BELOW | ANTISTATIC | BLACK |
| 3 | TOP COVER TAPE | - | MENTIONED BELOW | ANTISTATIC | TRANSPARENT |

| | | | | |
|----------------|-------------------------------|-----------------|-----------------------------|------------------|
| 4P | ø330.00±2.10 [12.992±.082] | ø100 [3.940] | 24.40 +2.00 [.960 +.790] | 30.40 [1.997] |
| NO OF POSITION | A | N (MIN) | W1 | W2 (MAX) |

| | | | | | | |
|----------------|-----------------------------|--------------------------|---------------------------|--------------------------|---------------------------|--------------------------|
| 4P | ø1.50 +0.10 [ø.059+.003] | 4.00±0.10 [.157±.003] | 16.00±0.10 [.629±.003] | 2.00±0.15 [.078±.005] | 11.50±0.10 [.453±.003] | 7.40±0.10 [.291±.003] |
| NO OF POSITION | D1 | P0 | P1 | P2 | F | K |

| | | | | | | |
|----------------|---------------------------|---------------------------|--------------------------|--------------------------|---------------------------|----------------------------|
| 4P | 24.00±0.30 [.944±.011] | 12.90±0.10 [.507±.003] | 1.75±0.10 [.068±.003] | 0.50±0.05 [.020±.001] | 12.14±0.50 [.477±.020] | ø1.50+0.10 [ø.059+.003] |
| NO OF POSITION | W | B | E | T | L | DO |

THIS DRAWING IS A CONTROLLED DOCUMENT. DWN: B.S.VISWESWARA 10FEB05
 CHK: M.SARVER
 APVD: M.SARVER
 PRODUCT SPEC: -
 APPLICATION SPEC: -
 WEIGHT: -
 CUSTOMER DRAWING

TE TE Connectivity
 DIP SWITCH, ADE-SMT SERIES

SIZE: A2 CAGE CODE: - DRAWING NO: C=1825058 RESTRICTED TO: -
 SCALE: 4:1 SHEET: 3 OF 3 REV: S2